

INSTRUCTION MANUAL
MODEL 375
TAPE RECORDING ELECTRONICS

August 1975



1305 Fair Avenue, Santa Cruz, CA 95060

(831) 458-0552

TABLE OF CONTENTS

| <u>SECTION</u> | | <u>PAGE</u> |
|----------------|--|-------------|
| 1.0 | GENERAL INFORMATION | 2 |
| 2.0 | INSTALLATION AND USE | 7 |
| 3.0 | OPERATION AND FUNCTIONAL DESCRIPTION | 9 |
| 4.0 | ALIGNMENT AND MAINTENANCE | 17 |
| | PARTS LIST | 23 |
| | SCHEMATICS | 28 |

SECTION 1.0 GENERAL INFORMATION

The Inovonics 375 is a compact, up-to-date magnetic recording electronics package, completely self-contained with integral power supply. Available in several versions, the 375 is equally well suited to new installations, or to improve the performance and reliability of older professional tape recorders.

The 375 is delivered with proper interconnect cabling for whatever tape transport is specified for use with it. When no specification is made, the unit is supplied with cabling for Ampex 350/351 series machines.

Among the features incorporated are:

Calibrated positions on Record and Reproduce gain controls.

Provision for remote switching of all monitor and equalization functions, and solid-state switching to eliminate contact noise problems.

3-speed equalization to accommodate any combination of NAB and IEC characteristics.

Harmonic and phase distortion nulling circuits.

Able to accommodate a wide variety of original-equipment and replacement heads.

Optional SYNC Reproduce Amplifier with independent equalization and automatic SYNC-INPUT monitor transfer switching (-03 version only).

1.1 SPECIFICATIONS

NOTE: Performance of a magnetic recording system is limited in part by the heads and tape employed. The Inovonics 375 is intended both for upgrading older recorders in broadcast and similar applications, as well as for new studio installations. Hence two sets of specifications are given, each with respect to the heads, tape and standards generally in use in each installation situation. A third group contains those specifications which are not application oriented.

1.1.1 Specifications derived using 3M 206 tape and a Taber full track replacement head assembly on an Ampex 351 transport.

Frequency Response (in Hz)

| | | |
|----------|-------------|----------|
| 15 ips | <u>+2dB</u> | 20 - 20k |
| 7.5 ips | <u>+2dB</u> | 20 - 15k |
| 3.75 ips | <u>+3dB</u> | 20 - 8k |

Signal-to-Noise Ratio (in dB, referred to a "peak" record level 6dB above 200nW/m, or approx. 3dB below 3% THD; 20Hz - 20kHz)

| | OVERALL | | STANDBY | |
|----------|---------|----------|---------|----------|
| | u'wtd. | NAB wtd. | u'wtd. | NAB wtd. |
| 15 ips | -67 | -76 | -76 | -87 |
| 7.5 ips | -69 | -77 | -76 | -86 |
| 3.75 ips | -66 | -74 | -72 | -83 |

Erase/Bias Frequency

100kHz

Erasure

70dB erasure of 500Hz signal recorded 3dB below tape saturation.

Recorded Distortion (at 15-mil wavelength bias peak - typical)

| | LIN out | LIN in |
|---------------------|---------|--------|
| Operating Level | .45% | .02% |
| 6dB above Op Level | 2% | .015% |
| 8dB above Op Level | 3% | .02% |
| 10dB above Op Level | 5.5% | 2.2% |

1.1.2 Specifications derived using 3M 250 tape, an Operating Level of 320nW/m and Nortronics 9227 (erase), 9203 (record) and 9213 (reproduce) heads - 70-mil track width format, typical of multi-track applications.

Frequency Response (in Hz)

| | | | |
|---------|------|----------|---|
| 30 ips | +2dB | 60 - 22k | (SYNC reproduce response essentially identical to normal overall) |
| 15 ips | +2dB | 30 - 22k | |
| 7.5 ips | +2dB | 20 - 16k | |

Signal-to-Noise Ratio (in dB, referred to approx. 640nW/m or 3% THD; 20Hz - 20kHz)

| | OVERALL | | SYNC | | STANDBY | |
|---------|---------|------|--------|------|---------|------|
| | u'wtd. | wtd. | u'wtd. | wtd. | u'wtd. | wtd. |
| 30 ips | -71 | -78 | -71 | -80 | -80 | -87 |
| 15 ips | -67 | -77 | -67 | -77 | -75 | -86 |
| 7.5 ips | -67 | -76 | -67 | -77 | -74 | -85 |

Erase/Bias Frequency

250kHz

Erasure

70dB erasure of 500Hz signal recorded 12dB above Operating level, or approximately 3dB below tape saturation.

Recorded Distortion (at 15-mil wavelength bias peak - typical)

| | LIN out | LIN in |
|--------------------|---------|--------|
| Operating Level | .5% | .15% |
| 3dB above Op Level | 1% | .3% |
| 6dB above Op Level | 2.5% | .8% |

1.1.3 Specifications Independent of Application

Equalization

3 speed with pushbutton selection, automatic switching between INTER and LOW when transport provides closure. Accommodates NAB, IEC (or mixed) characteristics for 3.75 through 30 ips operation.

Amplifier Distortion

Record:

<.1% THD at Op Level

<.25% THD 25dB above Op Level

Reproduce:

<.1% THD at Op Level

<.5% THD at +24dBm Line Output (clipping level +25dBm)

Input

Sensitivity: -20 to +8dBm (-8 to +8dBm with -01 option
input transformer)

Impedance: 10K bridging

Outputs

Line Output: feeds 600 line, balanced or unbalanced,
terminated or not, at +4 or +8dBm for Zero-VU.

Headphones: Front panel jack

Panel Controls

RECORD GAIN (with pre-set CAL position)

REPRO LEVEL (with pre-set CAL position)

MONITOR: selects between INPUT, REPRO and SYNC (-03 versions)

SAFE/READY

RECORD

EQUALIZATION: manual selection of HIGH, INTER or LOW.

POWER

Power Requirement

105-130 VAC (230V available) 50/60Hz, .3A (plus transport)

Size and Shipping Weight

3½" x 19" x 10"

15 lbs

SECTION 2.0 INSTALLATION AND USE

2.1 Upon receipt of the equipment, inspect for shipping damage. Should any be observed, notify the carrier immediately; if not, proceed as outlined below. It is suggested that the original shipping carton and materials be saved for possible future reshipment.

2.2 The 375 is packaged to mount in a standard 19-inch equipment rack, requiring 3½-inches of panel space. When replacing original electronics in an overbridge above the transport, it may be necessary to drill and tap an additional two holes to accommodate the 375 panel.

2.3 The signal, head and transport connectors are directly compatible with Ampex 350, 351 and 354 equipment. Units ordered for use with other transports or for use in stereo pairs are supplied with appropriate interconnect cabling.

2.4 Unless supplied otherwise to special order, units intended for mono or stereo installations are delivered properly aligned for use with 3M 206 tape at an operating level of 200nW/m, with Ampex 351-type heads (1.5mHy erase, 5-10mHy record, and 1Hy reproduce) and 100kHz bias. Units for multi-track use normally operate with lower inductance heads (0.5mHy erase, 4-5mHy record, and 400mHy reproduce), utilize 250kHz bias, and incorporate the optional SYNC reproduce amplifier. Heads with inductances other than those suggested above can be accommodated. Section 4.1.4.2 outlines the necessary changes.

2.5 As delivered, the 375 is calibrated to operate at a +4dBm signal level. Should operation at +8dBm be necessary, clip the jumper shunting the 4.7K resistor near the line output connector and recalibrate as described in paragraph 4.1.2.8.

2.6 The low source impedance of the 375 line output results in only about ½dB level change from an unloaded to 600 ohm loaded condition.

The 375 should, nevertheless, be connected to its intended load prior to final calibration.

2.7 Even with the optional input isolation transformer option supplied (-01 version only), the 375 input impedance is 10K ohms or greater. Should the equipment feeding the 375 require a terminating load, a 600-ohm resistor should be placed in parallel with the 375 input.

2.8 No provision for meter indication of bias or erase current is made, as the inherent stability of the circuitry is greater than that of the heads and meter at bias frequencies.

2.9 When two or more 375's are employed in dual or multi-track applications, the interconnecting cabling supplied delivers AC power to all units and to the transport, if it derives power from the electronics. The cabling also "slaves" all erase/bias amplifiers to a single oscillator, thereby avoiding bias "beats" or the necessity of synchronizing two or more oscillators.

SECTION 3.0 OPERATION AND FUNCTIONAL DESCRIPTION

3.1 OPERATION

3.1.1 The RECORD GAIN and REPRO LEVEL controls are provided with a detented CAL position at full CCW rotation. They are normally left in these positions except for temporary correction for an improperly recorded tape or abnormal line level. Range is adequate to record from a -20dBm line level (-8dBm with optional input transformer) and to produce normal line output from a tape under-recorded by 10dB.

3.1.2 The MONITOR buttons determine whether the line amplifier will derive its signal from the incoming program (INPUT), the reproduce head (REPRO), or in versions with -03 option, the record head (SYNC). When any button is only slightly depressed to release all three to their "out" position, the monitor selection is transferred to the rear panel REMOTE connector. On versions with the -03 option, monitor is automatically switched from SYNC to INPUT when entering the record mode.

3.1.3 The alternate-action SAFE/READY switch, when depressed, permits the 375 to enter the record mode when the transport is in "record". When this button is "out", the 375 will not enter the record mode, thereby preventing accidental erasure of a tape or that track of a dual or multi-track recording.

3.1.4 The RECORD button places the transport in the record mode. The button will not illuminate, though, nor will the 375 go into "record" unless the SAFE/READY button is depressed. In dual or multi-track installations, depressing any RECORD button will place the transport in the record mode; only those 375's in "ready" will record, however.

3.1.5 The EQUALIZATION buttons select record and reproduce equalization appropriate to the transport speed employed. Three independent sets of equalizers are provided, although most transports are only

dual speed units. In these cases the third position may be used for a European or other non-standard curve. In the event of use with a transport providing an equalization-switching pole on the speed switch, the equalization selection can be transferred to change automatically between INTER and LOW (if the transport is appropriately wired) by depressing an EQUALIZATION button slightly so that all three buttons are "out".

3.1.6 The alternate action POWER switch controls AC power to the 375 and to the transport, if it is powered by the electronics.

3.1.7 The PHONES jack is connected ahead of the output transformer through a 470 ohm resistor. It is suitable for headphone monitoring or as an unbalanced, uncalibrated line output for servicing.

3.1.8 The recessed slide switch behind the adjustment cover panel enables or defeats the linearization circuit, (see paragraph 4.2.1).

3.2 CIRCUIT DESCRIPTIONS

3.2.1 General

Electronic circuitry for the Recording, Reproducing and Erasing Amplifiers is contained on a single "piggy-backed" plug-in assembly. The lower board (Reproduce) carries the Reproduce, optional SYNC and Line Amplifiers; the upper board (Record), the Erase/Bias and Record Amplifiers. Another single PC assembly within the chassis contains the power supply and bias oscillator circuits.

3.2.2 Reproduce Amplifier (schematic 129000).

Signals from the reproduce head enter on pins 13 and 14. An optional head input transformer (-04 version only) can be strapped in to permit use of low (4-5mH) inductance heads. Resistor R1 is selected to dampen head resonance and yield smoothest playback response (see paragraph 4.1.2.4).

Transistors Q1 and Q2 form a complementary feedback-pair input stage, Q3 serving primarily as an emitter-follower buffer. DC feedback is maintained through R19 and R11, bypassed at audio frequencies by C2. AC feedback is routed through an appropriate equalization network by FET switches Q4, Q5 or Q6. A secondary function of Q3 is to provide a phase-inverted reproduce signal (at the collector) for the reproduce phase compensation circuit. This signal, coupled through C7, interacts with the in-phase emitter signal fed through R25 to provide an adjustment of reproduce phase shift to complement and cancel the phase shift which normally occurs during the recording process. FET switch Q7, normally on, defeats this compensation, except at the one speed for which the adjustment is made (see paragraph 4.2.2.2). IC2 imparts voltage gain to the reproduce signal, with R28, the REPRO CAL adjustment, providing a control over the gain and a means of obtaining a given signal level for a variety of head outputs. This amplified signal is fed through R29, bridged by the front panel REPRO LEVEL con-

trol, to the Line Amplifier.

3.2.3 SYNC Amplifier

The optional SYNC reproduce amplifier (-03 version only) is essentially identical to the Reproduce Amplifier just discussed, except that the head input transformer is always used, and the value of R53 is increased over that of its counterpart R3 to reduce overall gain. This is required as the record head used as a reproduce head has greater output than a true reproduce head of similar inductance.

3.2.4 Line Amplifier

FET's Q8, Q9 and Q28 perform an input switching function for the Line Amplifier, passing signals from the Reproduce Amplifier, input source, and SYNC Amplifier, respectively. The gates of these switching transistors are normally held at -20 volts, introducing an effective open circuit between the source and drain. When the gate is brought to ground potential either by the front panel MONITOR switch or through the REMOTE connector, the source-drain resistance drops, passing the selected signal.

Transistor Q29 and associated circuitry is part of the SYNC reproduce option (-03 version only), switching the line amplifier from SYNC to INPUT monitor when the 375 enters the record mode.

R34, 36, C10 and 12 are part of an active low-pass filter with cutoff beginning at about 30kHz. This aids in reducing whatever bias signal might appear at the line output, primarily in the SYNC reproduce mode.

IC1 performs the voltage gain function of the Line Amplifier, with gain established by feedback resistors R35 and 37. Transistors Q10, Q11 and associated components provide the output current required for driving low impedance loads and long cables. Protection from output short circuits is afforded by diodes CR3 and 4.

3.2.5 Reproduce Line Amplifier

Although not available as a factory-installed option, provision is included in the PC artwork to incorporate a second Line Amplifier dedicated to the reproduce function. Use of this user-installed option is relegated to special applications or effects generation.

3.2.6 Record Amplifier (Schematic 129100)

Input signals from the front panel RECORD-GAIN control are further attenuated by the RECORD LEVEL calibration control, R1. Resistors R2 and R3, capacitors C1 and 2 and first gain stage IC1 form an active low-pass filter with cutoff beginning about 30kHz. The filter removes RF and other spurious signals outside the audible range which might otherwise cause high frequency overloading during recording. A portion of the amplified input signal is directed to the Line Amplifier through RECORD CAL control R7 for source monitoring.

C4 imparts a 6dB/octave rising characteristic to the input signal as required for recording pre-emphasis. Depending upon the tape speed and equalization characteristic used, however, only a rise at very high frequencies or no increase at all may be required. C7, connected in the feedback path of IC2, therefore provides a complementary falling characteristic which cancels the effect of C4. Record equalization trimmers R34, 35 and 36 are introduced into the IC2 feedback loop when the appropriate FET switch is activated, and "shelf" the falling characteristic. This affords control over the inflection point of the effective pre-emphasis curve provided by the combined network characteristics.

R11 and C5 modify the pre-emphasis curve slightly, causing a droop in the 5kHz-and-above region. These component values can be changed for smoothest overall response, but are supplied as the best compromise for heads typical of the application for the version ordered.

A 3dB boost at 50Hz (required for the NAB record characteristic) is effected by shunting C4 by R10. FET Q5 is normally off, but can be turned on for one or more equalization positions if IEC or other "flat-low-end" record curves are desired. This is accomplished on the Power Supply PCB (see paragraph 3.2.9).

CR3 and 4, IC3, and associated circuitry forms the "linearizer" network. When Q9 is turned on by activating the LINEARITY switch under the adjustment cover panel, a variable non-linear characteristic can be imparted to the record signal that when properly adjusted cancels a major portion of the tape-generated third harmonic distortion (see section 4.2.1).

IC4 and associated components form the constant-current head driver stage. Relay K1 connects the record head to the output of IC4 in the record mode, and to the input of the SYNC amplifier for SYNC reproduce (-03 version only). A bias trap composed of L2/C22, C24 and L3/C23 keeps bias from disturbing the head driver stage or overloading the SYNC amplifier. FET switch Q10 opens the input to IC4, except when the 375 is in the record mode.

3.2.7 Erase/Bias Amplifier

The bias signal generated on the Power Supply PC assembly is raised to the required power level for erasure and bias by Q1, 2, 3 and 4. Q1 and 2 raise the 1Vrms signal to a proper level to just saturate the class "C" output stages, Q3 and 4. R23 and 25 control drive and symmetry, respectively, and are factory-adjusted.

Transformer T1 raises the amplifier output voltage to approximately the 150 volts P-P required for erase head driving requirements.

Capacitor C16 resonates the erase head at the operating frequency. C25 and BIAS ADJUST control R50 couple the required bias signal to the record head. In the case of erase heads of lower than nominal inductance, an inductor, L4, is inserted in series to bring erase head

inductance up to the nominal value (see paragraph 4.1.4.2).

3.2.8 Record Logic Timing

In order to insure inaudible "punch-in's" and "punch-out's", the 375 must enter the record mode with the proper sequence of events.

IC5, C26 and R58 form a Miller Integrator which generates a linear ramp when the unit goes into "record." At the start of the ramp, the Line Amplifier is first switched from SYNC to INPUT monitor (-03 version only). Next K1 is energized, transferring the record head to the output of the record amplifier. A short delay introduced by R45 and C19 applies the input signal to the head driver stage concurrent with the relay closure. At this point the bias and erase field begins to build. Upon leaving the record mode, the opposite chain of events occurs. "Punch-in" and "Punch-out" time is symmetrical at about 100 milliseconds.

3.2.9 Power Supply (Schematic 129200)

Triac Y1 operates in conjunction with the front-panel POWER switch to control primary AC power to the 375 and associated tape transport, if deriving power from the unit. This saves the switch contacts from heavy surge currents and inductive loads.

The chassis-mounted power transformer applies AC to the bridge rectifier, diodes CR1-4. A bipolar "raw" supply of about ± 30 volts appears across filter capacitors C1 and C2.

IC1 is the positive supply regulator, with Q1 connected to provide up to 250mA, at +20 volts (nominal). Resistor R3 and circuitry internal to IC1 limit the available current to this value and establish short-circuit protection. The negative power source is referenced to the regulated positive supply, and utilizes Q3 and Q4 as a differential input pair driving the compound output stage Q5/Q6. CR6, 7, and

8 and R1 provide current limiting and short-circuit protection.

Transistors Q10 and 11 are connected in an emitter-coupled multi-vibrator configuration, oscillating at the erase/bias frequency established by the value of C7 and trimmed by FREQ adjustment R33. Q12 amplifies the oscillator signal and applies it to the parallel-resonant network L1/C8, transforming the square wave into sine wave form. Transistor Q9, an emitter-follower buffer stage, provides a low output impedance for the 1V rms bias oscillator signal.

Transistor Q7 and its associated components form part of the equalization switching system, placing the 375 in INTER EQ when no other command is received, either from the front panel EQUALIZATION switch, or a transport speed switch closure.

Transistor Q8, normally off, disables the reproduce (and SYNC, on -03 versions) phase compensation network, except at the one speed for which the network is optimized and for which a strap is connected (see section 4.2.2).

Similarly, the record amplifier pre-emphasis characteristic includes a low frequency boost, as required for NAB equalization, which can be defeated at one or more speeds by the installation of diodes as shown on the schematic.

SCR1, a silicon controlled rectifier, replaces the electro-mechanical "record" relay usually required by Ampex 300-, 350-, and 440- series transports. The SCR is triggered "on" in the transport PLAY mode when the front panel RECORD button is depressed, and latches until the transport leaves the PLAY mode. An optical coupler A1 and transistor Q2 isolate the ground-referenced Record and Erase/Bias Amplifier logic signal from the transport control function voltages.

SECTION 4.0 ALIGNMENT AND MAINTENANCE

4.1 Routine Calibration

4.1.1 Equipment Required:

Head Demagnetizer
Appropriate Reproducer Alignment Tapes
Audio Oscillator
AC Voltmeter

4.1.2 REPRODUCE

- 4.1.2.1 Depress INPUT monitor button. Clean and demagnetize all heads, moving very slowly while the demagnetizer is near the heads, and withdrawing it about a yard from the head assembly before unplugging it.
- 4.1.2.2 Depress REPRO monitor button and thread an alignment tape appropriate for the equalization to which the electronics is switched.
- 4.1.2.3 While reproducing the highest frequency on the tape, adjust reproduce head azimuth for maximum output.
- 4.1.2.4 If the resonance of the reproduce head with its cable is near the top of the passband (as is usually the case for best signal-to-noise performance), a peak in response will be observed at the highest frequencies. R1 on the Reproduce Amplifier card is provided to damp this resonance. To determine whether its value is correct for the head used, set High Speed H.F. control so that 5kHz playback is flat with respect to the reference frequency tone on the alignment tape. Note response at the highest frequencies, and raise the value of R1 to increase, or lower to decrease, this level.
- 4.1.2.5 Set H.F. control for smoothest response from reference frequency to highest frequency.

- 4.1.2.6 If alignment tape track width is the same as reproducer track width, set L.F. control for smoothest response from reference frequency to lowest frequency. If not, as with full-track tapes and half-track reproduce heads, wait until step 4.1.5.4 to trim the control.
- 4.1.2.7 Repeat the preceding two steps for the other speeds. It is advisable to make final azimuth setting at the lowest speed to be used.
- 4.1.2.8 Turn front panel REPRO LEVEL control fully ccw to CAL position and adjust R34 REPRO CAL on Reproduce card for an indication of Zero-VU while reproducing a reference tone recorded to the desired operating level. If it is wished to operate into a +8dBm line, remove the jumper across the 4.7K resistor near the output connector before making this adjustment.

4.1.3 SYNC REPRODUCE (-03 version only)

The SYNC reproduce function, on 375's so equipped, is aligned in the same manner as the normal reproduce section described in 4.1.2.1 through 4.1.2.7. Playback is from the record head in this case, and there is no front panel level adjustment.

4.1.4 ERASE/BIAS

- 4.1.4.1 The Model 375 is available with the option of 100kHz (-00 version) or 250kHz (-02 version) erase/bias frequencies. The lower frequency is intended for operation with older metal heads, as are found on the earlier Ampex vacuum-tube recorders. Heads for operation at 250kHz must be of lower inductance and greater efficiency.
- 4.1.4.2 For 100kHz operation the 375 is designed to drive an erase head in the 1.2 to 1.8mHy range. At 250kHz, the requirement

is 0.4 to 0.6mHy. If a head of lower inductance than specified is intended for use at either frequency, remove the shorting strap in place of L4 on the Record PCB and install a choke coil, the inductance of which when added to the erase head inductance, will equal 1.5mH (in the case of 100kHz operation), or 0.5mH (for 250kHz units). Similarly, the optional (-04 version only) head input transformer on the Reproduce PCB can be strapped as shown on the board to accommodate low-Z (4-5mHy reproduce heads).

- 4.1.4.3 NOTE: Present-day tapes with higher coercivity oxides may require a biasing procedure slightly modified from the traditional 15-mil wavelength "peak" method described below. Follow tape manufacturer's recommendation for best performance.

Depress the REPRO monitor button, connect an audio oscillator to the INPUT connector, and thread transport with a good sample of the type of tape to be used subsequently. Place machine in record mode at 15 ips and adjust input to 1kHz at about operating level; adjust R50 BIAS control for maximum reproduced signal. (Use 500Hz at 7½ ips on units which do not operate at 15 ips.)

4.1.5 RECORD

- 4.1.5.1 With conditions as for 4.1.4.3 above, place recorder in record mode at highest speed and set input signal to 700Hz at +4dBm (+8dBm if reproduce was calibrated for this level). Reduce level by about 10dB in the case of transports which do not operate at 15 ips.
- 4.1.5.2 Raise the frequency to 15kHz and adjust the record head azimuth for maximum output. Note: on -03 versions, the adjustment of record head azimuth was made in SYNC calibration and need not be repeated.

- 4.1.5.3 Set record pre-emphasis by adjusting R34 on the Record PCB for smoothest response from reference frequency up.
- 4.1.5.4 If incompatibility of alignment tape track width to reproducer track width prevented setting reproduce L.F. controls in paragraph 4.1.2.6, adjust R14 on the Reproduce PCB now for flattest over-all response.
- 4.1.5.5 Set equalization for lower speeds using R34 and R36 for INTER and LOW speeds, respectively. The input level should be reduced by 10dB for alignment of $7\frac{1}{2}$ ips and lower speeds.
- 4.1.5.6 Switch front panel RECORD GAIN and REPRO LEVEL controls fully ccw to CAL position. With input of normal line level and of the same frequency as the reference tone on the alignment tape used, set R1 on Record PCB for an indication of Zero-VU on the meter.
- 4.1.5.7 Depress INPUT monitor button and adjust R7 on the record PCB for an indication of Zero-VU on the meter.

4.2 SPECIALIZED ADJUSTMENTS

4.2.1 Linearizer

4.2.1.1 The 375 is equipped with a "linearizer" circuit which, when properly adjusted, can cause a significant reduction in tape-generated odd harmonic distortion. This circuit is enabled or defeated by a slide switch located under the adjustment cover panel.

4.2.1.2 Precise calibration of the linearizer requires a low distortion sine wave oscillator and a wave analyzer type of distortion meter. The procedure, in this case, is to record a 1kHz tone at 6dB above operating level and adjust R39 on the Record PCB for the minimum 3kHz distortion component reproduced from the tape.

4.2.1.3 An alternate method of adjustment requires only a typical studio program equalizer which can be peaked at 3kHz and give at least 15dB rejection at 1kHz. With this method, the output of the 375 is routed through the equalizer to the monitor speaker system, and R39 adjusted for minimum perceived distortion.

4.2.2 Phase Compensation

4.2.2.1 The 375 is equipped with a phase correction network in both the normal Reproduce and SYNC reproduce (-03 version only) Amplifiers. The networks, operative at one selected speed only, are adjusted for best reproduced square wave response.

4.2.2.2 The phase corrector is enabled at the selected speed by strapping a jumper between PH COMP and either H(HIGH), I(INTER) or L(LOW) on the Power Supply PCB. The only way to adjust the network(s) is to record a 3kHz square wave at

the selected speed, and adjust R25 (and R75 on -03 versions) for a best-looking square wave on playback as monitored on an oscilloscope.

4.3 SERVICE NOTES

- 4.3.1 Meter Lamps - The meter is illuminated by two long life #388 lamps which are considerably under-voltaged. In the event it eventually becomes necessary to replace one, remove the top cover and remove the 3/16" hex threaded spacer retaining the socket of the burned out lamp.
- 4.3.2 All illuminated switch buttons - Squeeze the button from top and bottom and pull straight off. The #387 lamp can be removed carefully with a pair of long-nosed pliers.

| SCHEMATIC REF. NO. | PART NUMBER | DESCRIPTION | MFG. | MANUFACTURER PART NUMBER |
|----------------------------|--------------------|--|------------|-----------------------------|
| | 128200/ 128201A | <u>REPRODUCE PCB ASSY</u> (SCHEMATIC 129000) | | |
| C1 | 0904 | Capacitor, 25uF, 25V | Sprague | TE1207 |
| C2, 22 | 0906 | " 100uF, 3V | " | TE1059.5 |
| C3, 14, 23, 34 | 0810 | " 100pF | Elmenco | DM15-101J |
| C4, 5, 6, 24, 25, 26 | 0862 | " 0.01uF, 100V | Sprague | 225P10391 |
| C7, 27 | 0820 | " 680pF | Elmenco | DM19-681J |
| C8, 13, 28 | 0801 | " 10pF | " | DM15-100J |
| C9, 11, 29 | 0901 | " 5uF, 25V | Sprague | TE1202 |
| C10 | 0811 | " 120pF | Elmenco | DM15-121J |
| C12 | 0832 | " 62pF | " | DM15-620J |
| CR1 - 6 | 1100 | Diode, Silicon 1N4009 | FSC/GE | |
| IC1, 2, 3 | 1300 | Integrated Cct. Type 748-C | Signetics | |
| Q1, 3, 21, 23 | 1210 | Transistor, SE4010 | FSC/NSC | |
| Q2, 11, 22, 29 | 1205 | " 2N3645 | " | |
| Q4 - 9, 24 - 28 | 1211 | " MPF111 | NSC/Motor. | |
| Q10 | 1204 | " 2N3567 | NSC/FSC | |
| R5, 55 | 0511 | Resistor, adjustable 20K | Spectrol | 43P-203 |
| R6, 7, 28, 56, 57, 78 | 0510 | " " 10K | " | 43P-103 |
| R12, 13, 14, 62, 63, 64 | 0519 | " " 2meg | " | 43P-205 |
| R25, 75 | 0514 | " " 100K | " | 43P-104 |
| T1, 2 | 1500 | Transformer, head matching | Beyer | 145/BV 35704 |

| SCHEMATIC REF. NO. | PART NUMBER | DESCRIPTION | MFG. | MANUFACTURER PART NUMBER |
|-------------------------|--------------------|---|-----------|--------------------------|
| | 128300/ 128301A | <u>RECORD PCB ASSY</u> (SCHEMATIC 129100) | | |
| C1, 25 | 0827 | Capacitor, 300pF | Elmenco | DM15-301J |
| C2 | 0814 | " 220pF | " | DM15-221J |
| C3, 6, 18, 21, 27 | 0801 | " 10pF | " | DM15-100J |
| C4 | 0850 | " 0.001uF, 100V | Sprague | 225P10291 |
| C5 | 0854 | " 0.0022uF, 100V | " | 225P22291 |
| C7, 8, 9, 10, 11, 12 | 0862 | " 0.01uF, 100V | " | 225P10391 |
| C13, 14 | 1053 | " 2.2uF, 20V | Matsuo | DTSA1-2002-225M |
| C23 (-00) | 0834 | " 2700pF | Elmenco | DM19-272J |
| " (-01) | 0828 | " 750pF | " | DM19-751J |
| C16 (-00) | 0825 | " 1800pF | " | DM19-182J |
| " (-01) | 0821 | " 820pF | " | DM19-821J |
| C17, 28 | 0901 | " 5uF, 25V | Sprague | TE1202 |
| C19, 26 | 0867 | " 0.1uF, 100V | " | 225P10491 |
| C20 | 0810 | " 100pF | Elmenco | DM15-101J |
| C22 (-00) | 0829 | " 3000pF | " | DM19-302J |
| " (-01) | 0828 | " 750pF | " | DM19-751J |
| C24 (-00) | 0829 | " 1000pF | " | DM19-102J |
| " (-01) | 0828 | " 470pF | " | DM19-471J |
| CR1 - 6 | 1100 | Diode, Silicon 1N4009 | FSC/GE | |
| IC1 - 5 | 1300 | Integrated Cct. Type 748-C | Signetics | |
| K1 | 1904 | Relay, SPDT | Sigma | 191TE1C1-12G |
| L2, 3 (-00) | 1403 | Inductor, 1mHy | Delevan | 2500-28 |
| L2, 3 (-01) | 1401 | " 560uHy shielded | Nytronics | SWD 560 |
| L5, 6 | 1409 | " 220uHy | Delevan | 1537-92 |

| SCHEMATIC REF. NO. | PART NUMBER | DESCRIPTION | MFG. | MANUFACTURER PART NUMBER |
|---------------------------------|-------------------|---|-------------|-----------------------------|
| Q1 | 1210 | Transistor, SE4010 | FSC/NSC | |
| Q2, 11 | 1205 | " 2N3645 | " | |
| Q3 | 1212 | " 40319 | RCA | |
| Q4 | 1200 | " 2N2102 | RCA/NSC | |
| Q5 - 10 | 1211 | " MPF111 | NSC/Motor | |
| Q12, 13 | 1204 | " 2N3567 | FSC/NSC | |
| R1, 7, 34, 35, 37, 38, 39 | 0510 | Resistor, adjustable 10K | Spectrol | 43P-103 |
| R23 | 0557 | " " 2K | Helipot | 91AR2K |
| R25 | 0556 | " " 1K | " | 91AR1K |
| R36 | 0511 | " " 20K | Spectrol | 43P-203 |
| R50 | 0513 | " " 50K | " | 43P-503 |
| T1 | 127000 | Transformer, Bias Amplifier | (Inovonics) | |
| | 129400/ 129401 | <u>POWER SUPPLY PCB ASSY</u> (SCHEMATIC 129200) | | |
| A1 | 1307 | Optical coupler | Fairchile | FCD 820 |
| C1, 2 | 0910 | Capacitor, 500uF, 50V | Sprague | TVA1315 |
| C3, 4 | 1053 | " 2.2uF, 20V | Matsuo | DTSA1-2002- 225M |
| C5 | 0850 | " 0.001uF, 100V | Sprague | 225P10291 |
| C6 | 0827 | " 300pF | Elmenco | DM15-301J |
| C7 (-00) | 0857 | " 0.0039uF, 100V | Sprague | 225P39291 |
| " (-01) | 0852 | " 0.0015uF, 100V | " | 225P15291 |
| C8 (-00) | 0834 | " 2700pF | Elmenco | DM19-272J |
| " (-01) | 0828 | " 750pF | " | DM19-751J |
| C9 | 0867 | " 0.1uF, 100V | Sprague | 225P10491 |

| SCHEMATIC REF. NO. | PART NUMBER | DESCRIPTION | MFG. | MANUFACTURER PART NUMBER |
|--|----------------|-------------------------------------|-------------|-----------------------------|
| CR1 - 4 | 1125 | Diode, Silicon Rectifier 1N4005 | ITT | |
| CR6 - 12 | 1100 | " Silicon 1N4009 | FSC/GE | |
| IC1 | 1301 | Integrated Cct. Type 723-C | NSC/Tldyn. | |
| L1 (-00) | 1403 | Inductor, 1mHy | Delevan | 2500-28 |
| " (-01) | 1400 | " 560uHy | " | 2500-16 |
| Q1, 6 | 1213 | Transistor, 2N5294 | RCA | |
| Q2, 5, 9, 10, 11 | 1204 | " 2N3567 | FSC/NSC | |
| Q3, 4, 7, 8, 12 | 1205 | " 2N3645 | " | |
| R32 | 0556 | Resistor, adjustable 1K | Helipot | 91AR1K |
| R33 | 0564 | " " 200K | " | 91AR200K |
| SCR1 | 1151 | Silicon Controlled Rectifier, C103B | GE | |
| Y1 | 1152 | Triac, T2500B | RCA | |
| <u>CHASSIS-MOUNTED ELECTRONIC COMPONENTS</u> | | | | |
| C1, 2 | 0872 | Capacitor, 0.01uF, 600V | Sprague | 6PS-S10 |
| F1 | 2706 | Fuse, 3A | | |
| F2 | 2702 | " 1/2A | | |
| I1 - 9 | 2012 | Indicator Lamp, Type 387 | CM/Norelco | |
| R1, 2 | 0601 | Potentiometer, 100K w/ SPST Switch | Allen/Brad. | 70K4N040S 104UA |

| SCHEMATIC REF. NO. | PART NUMBER | DESCRIPTION | MFG. | MANUFACTURER PART NUMBER |
|-----------------------|----------------|-----------------------------------|-------------|-----------------------------|
| S1 | 1820 | Switch, RECORD | Switchcraft | 67012 series |
| S2 | 1819 | " MONITOR, SAFE/READY | " | " |
| S3 | 1818 | " EQUALIZATION, POWER | " | " |
| S4 | 1817 | " LINEARITY | Cont-Wirt | GF 323/G-02- |
| S5 | 1817 | " LINE TERM. | " | 70 |
| T1 | 1502 | Transformer, optional input | UTC | 0-37 |
| | 1503 | (shield for input transformer) | " | 0-17 |
| T2 | 109000 | Transformer, output | | |
| T3 | 130100 | " power | | |
| | 2800 | Meter, VU - with illumination kit | Modutec | 2BA-AVU-000- AB-KW/BA1 |

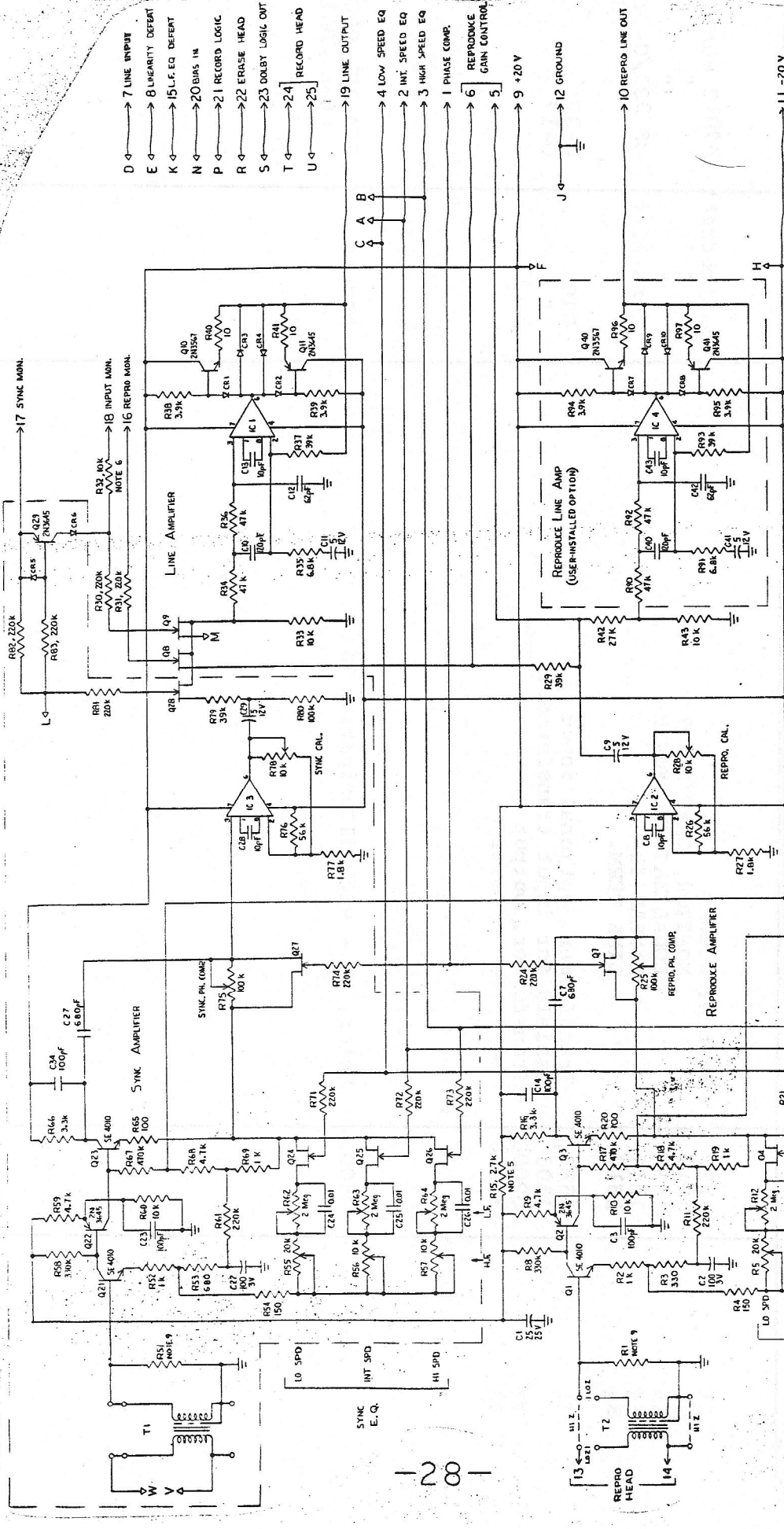

- D ← 7 LINE INPUT
- E ← 8 LINEARITY DEFEAT
- K ← 15 L.F. EQ DEFEAT
- N ← 20 BIAS IM
- P ← 21 RECORD LOGIC
- R ← 22 ERASE HEAD
- S ← 23 DOLBY LOGIC OUT
- T ← 24
- U ← 25

- 19 LINE OUTPUT
- 4 LOW SPEED EQ
- 2 INT. SPEED EQ
- 3 HIGH SPEED EQ
- 1 PHASE COMP
- 6 REPRODUCE GAIN CONTROL
- 5
- 9 +20V
- 12 GROUND
- 10 REPRO LINE OUT
- 11 -20V

REF. DESIG. USED

| | |
|----|---------------------|
| C | 1-14, 22-34, 40-43 |
| CR | 1-0 |
| IC | 1-4 |
| Q | 1-11, 21, 29, 40-41 |
| R | 1-43, 51-63, 90-97 |
| T | 1, 2 |

NOTES:
 UNLESS OTHERWISE INDICATED
 1. FIXED RESISTORS 24-WATT 10%, VALUE IN OHMS
 2. CAPACITORS ARE P/N 1000
 3. CAPACITORS ARE P/N 100
 4. IC'S ARE P/N 1000
 5. R15 IS 5.6K WHEN SYNC AMP ELIMINATED
 6. R2 JUMPED
 7. T1 AND T2 ARE P/N 1500
 8. T1 AND T2 ARE P/N 1500
 9. SELECTED FOR BEST RESPONSE WITH HEAD USED

316

MD. TRAPAZZI
 U.M. 4-23-79

SCHEMATIC
 REPRODUCE BOARD

129000

E

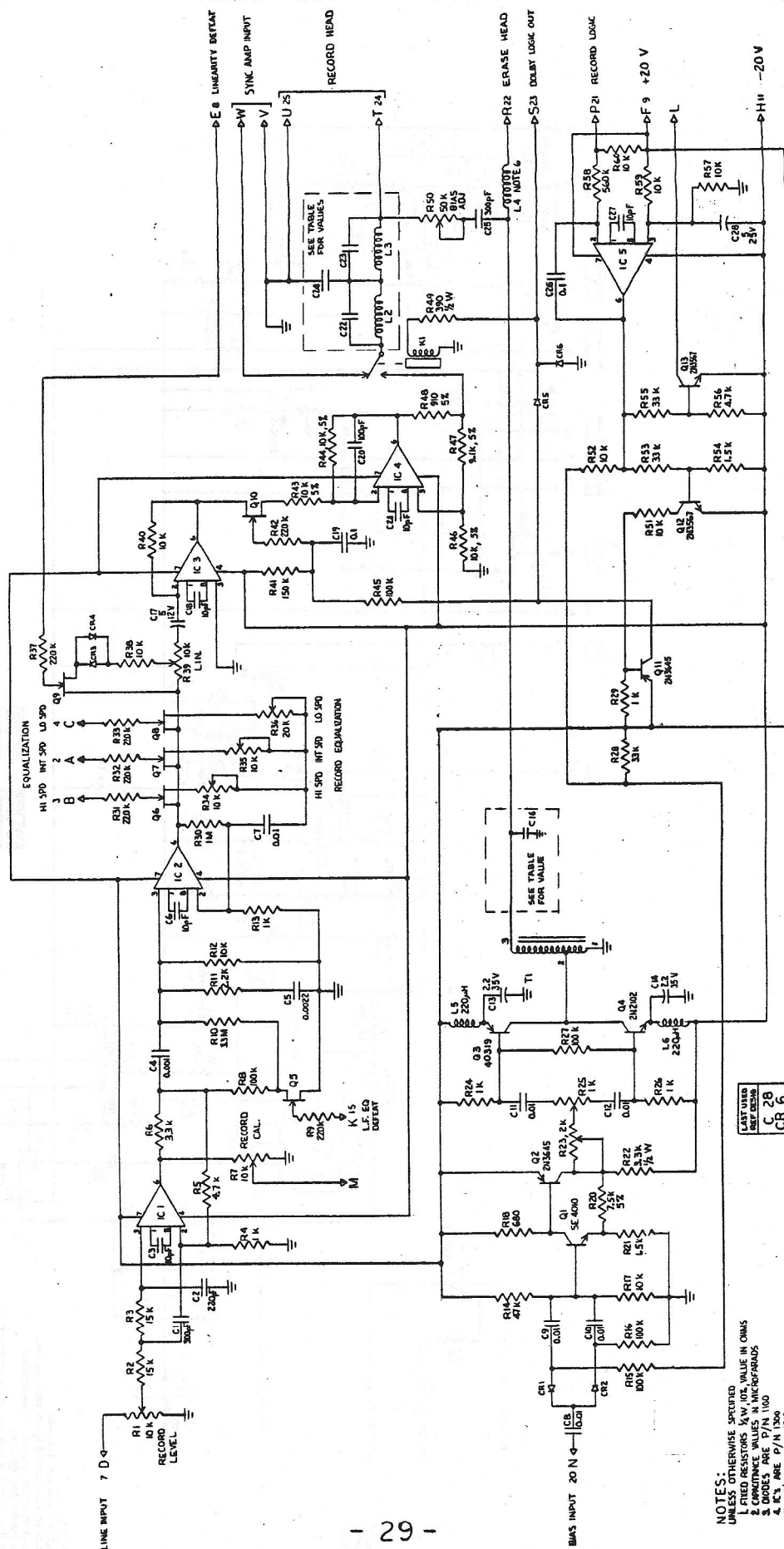

| VERSION | C23 | C16 | C22 | C24 | L2,3 |
|----------|--------|--------|--------|--------|-------|
| 1283305 | 2700pF | 1800pF | 3000pF | 1000pF | 1 mH |
| 1283301 | 750pF | 800pF | 750pF | 470pF | 500µH |
| 250 MINS | | | | | |

| NOT USED | NOT USED |
|----------|----------|
| C15 | L1 |
| C16 | L2 |
| C17 | L3 |
| C18 | L4 |
| C19 | L5 |
| C20 | L6 |
| C21 | L7 |
| C22 | L8 |
| C23 | L9 |
| C24 | L10 |

NOTES:
 UNLESS OTHERWISE SPECIFIED
 1. FILLED RESISTORS ARE 1/4 WATT VALUES IN OHMS
 2. FILLED CAPACITORS ARE 50V MICROFARADS
 3. DOBBES ARE P/N 110
 4. R'S ARE P/N 1300
 5. FET'S ARE P/N 1211
 6. ADD AS NECESSARY TO BRING ERASE HEAD CIRCUIT INDUCTANCE TO 1.5µH (100 MINS)

| | | | | | |
|--------------------|-----|------|--------------|------|-------|
| 778 | REV | DATE | BY | CHKD | APP'D |
| 1 | | | | | |
| INDVONICS | | | SCHEMATIC | | |
| Circuit No. 4-3274 | | | RECORD BOARD | | |
| TITLE | | | / 01 | | |
| PARTS | | | 129100 | | |
| DRAWN | | | D | | |

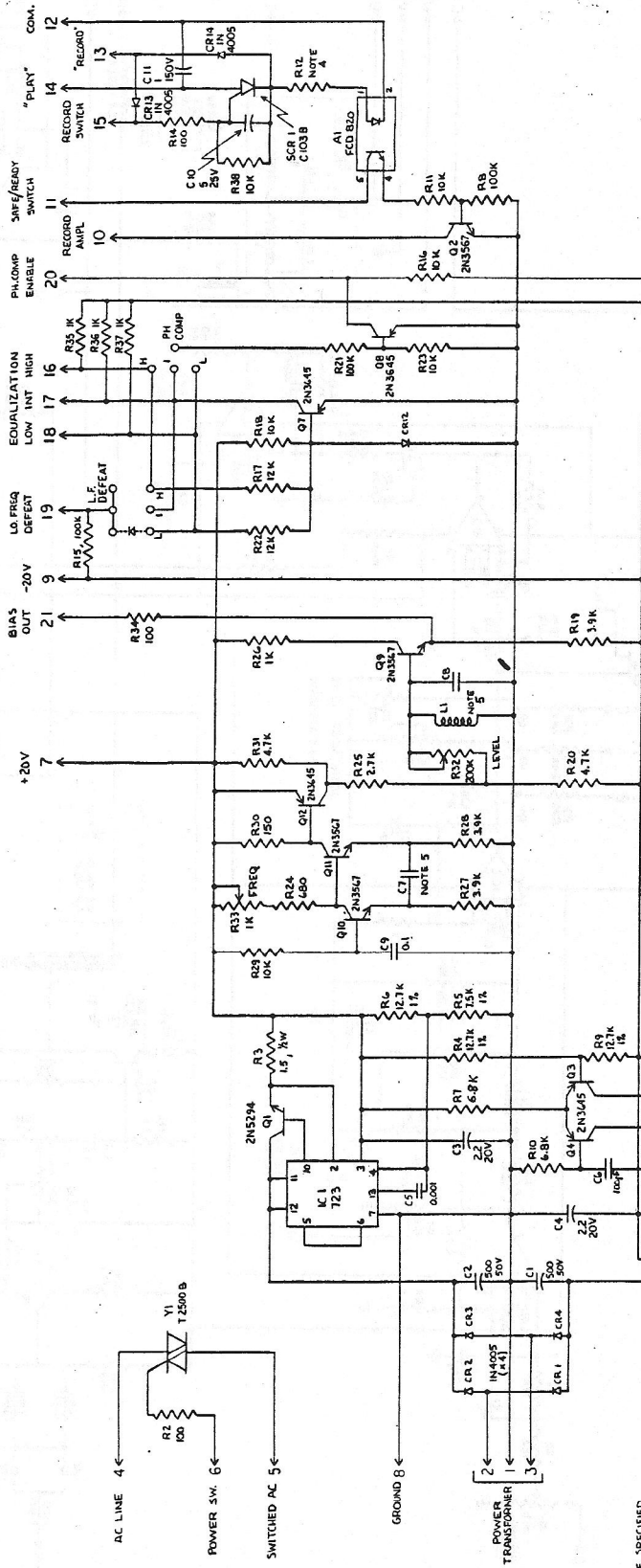

REF DESIG
NOT USED
CR 5

REF DESIG
REF DESIG
A 11
C 14
IC 1
L 1
O 12
R 38
SCR 1

NOTES:
UNLESS OTHERWISE SPECIFIED
1. FIXED RESISTORS 1/4 W, 10% VALUE IN OHMS
2. CAPACITANCE VALUES IN MICROFARADS
3. DIODES ARE 1/4 IN DIA
4. R.T. IS 10 K 1/4 W FOR 24 VOL TRANSPORT LOCK

| VERSION | L1 | C7 | C8 |
|---------|-------|--------|--------|
| 123400 | 1 mH | 0.0039 | 2700pF |
| 123401 | | | |
| 123402 | 560µH | 0.0018 | 750pF |

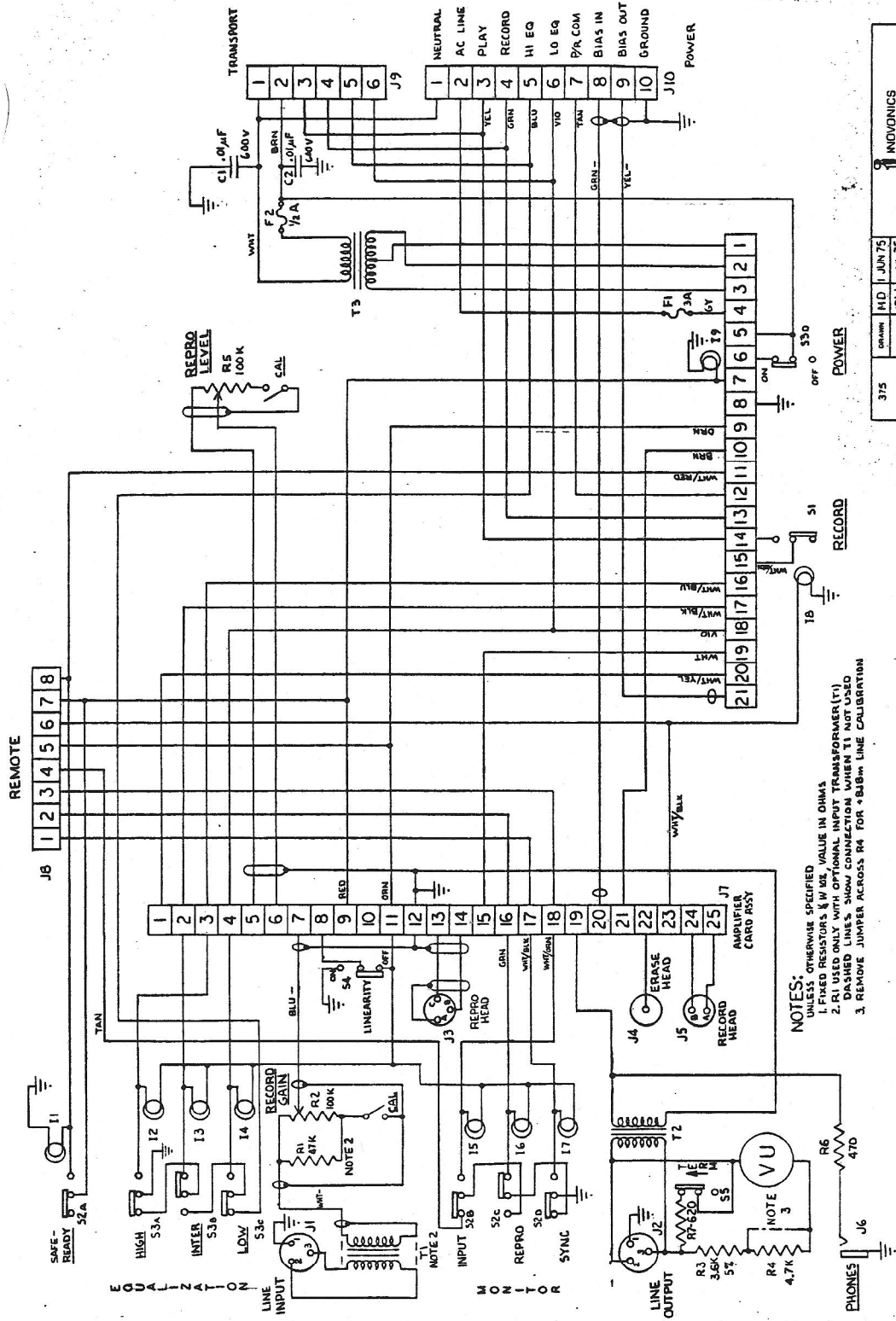

NOTES:
 UNLESS OTHERWISE SPECIFIED
 1. FIXED RESISTORS & W. OR. VALUE IN OHMS
 2. R1 USED ONLY WITH OPTIONAL INPUT TRANSFORMER (T1)
 DASHED LINES SHOW CONNECTION WHEN T1 NOT USED
 3. REMOVE JUMPER ACROSS R4 FOR 480W LINE CALIBRATION

| | | | |
|-------------|-----|--------|-------------|
| 375 | MD | JUN 75 | INDVONICS |
| CHECKED | JBM | JUL 75 | 375 CHASSIS |
| APPROVED | | | |
| TOLERANCE | | | |
| MATERIAL | | | |
| FINISH | | | |
| PH. 1: 01 | | | |
| PH. 2: 00 | | | |
| PH. 3: 00 | | | |
| PH. 4: 00 | | | |
| PH. 5: 00 | | | |
| PH. 6: 00 | | | |
| PH. 7: 00 | | | |
| PH. 8: 00 | | | |
| PH. 9: 00 | | | |
| PH. 10: 00 | | | |
| PH. 11: 00 | | | |
| PH. 12: 00 | | | |
| PH. 13: 00 | | | |
| PH. 14: 00 | | | |
| PH. 15: 00 | | | |
| PH. 16: 00 | | | |
| PH. 17: 00 | | | |
| PH. 18: 00 | | | |
| PH. 19: 00 | | | |
| PH. 20: 00 | | | |
| PH. 21: 00 | | | |
| PH. 22: 00 | | | |
| PH. 23: 00 | | | |
| PH. 24: 00 | | | |
| PH. 25: 00 | | | |
| PH. 26: 00 | | | |
| PH. 27: 00 | | | |
| PH. 28: 00 | | | |
| PH. 29: 00 | | | |
| PH. 30: 00 | | | |
| PH. 31: 00 | | | |
| PH. 32: 00 | | | |
| PH. 33: 00 | | | |
| PH. 34: 00 | | | |
| PH. 35: 00 | | | |
| PH. 36: 00 | | | |
| PH. 37: 00 | | | |
| PH. 38: 00 | | | |
| PH. 39: 00 | | | |
| PH. 40: 00 | | | |
| PH. 41: 00 | | | |
| PH. 42: 00 | | | |
| PH. 43: 00 | | | |
| PH. 44: 00 | | | |
| PH. 45: 00 | | | |
| PH. 46: 00 | | | |
| PH. 47: 00 | | | |
| PH. 48: 00 | | | |
| PH. 49: 00 | | | |
| PH. 50: 00 | | | |
| PH. 51: 00 | | | |
| PH. 52: 00 | | | |
| PH. 53: 00 | | | |
| PH. 54: 00 | | | |
| PH. 55: 00 | | | |
| PH. 56: 00 | | | |
| PH. 57: 00 | | | |
| PH. 58: 00 | | | |
| PH. 59: 00 | | | |
| PH. 60: 00 | | | |
| PH. 61: 00 | | | |
| PH. 62: 00 | | | |
| PH. 63: 00 | | | |
| PH. 64: 00 | | | |
| PH. 65: 00 | | | |
| PH. 66: 00 | | | |
| PH. 67: 00 | | | |
| PH. 68: 00 | | | |
| PH. 69: 00 | | | |
| PH. 70: 00 | | | |
| PH. 71: 00 | | | |
| PH. 72: 00 | | | |
| PH. 73: 00 | | | |
| PH. 74: 00 | | | |
| PH. 75: 00 | | | |
| PH. 76: 00 | | | |
| PH. 77: 00 | | | |
| PH. 78: 00 | | | |
| PH. 79: 00 | | | |
| PH. 80: 00 | | | |
| PH. 81: 00 | | | |
| PH. 82: 00 | | | |
| PH. 83: 00 | | | |
| PH. 84: 00 | | | |
| PH. 85: 00 | | | |
| PH. 86: 00 | | | |
| PH. 87: 00 | | | |
| PH. 88: 00 | | | |
| PH. 89: 00 | | | |
| PH. 90: 00 | | | |
| PH. 91: 00 | | | |
| PH. 92: 00 | | | |
| PH. 93: 00 | | | |
| PH. 94: 00 | | | |
| PH. 95: 00 | | | |
| PH. 96: 00 | | | |
| PH. 97: 00 | | | |
| PH. 98: 00 | | | |
| PH. 99: 00 | | | |
| PH. 100: 00 | | | |

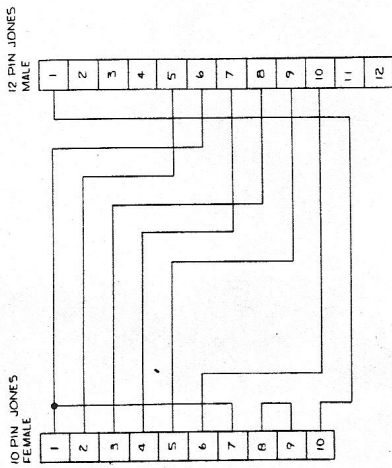

AMPEX 300

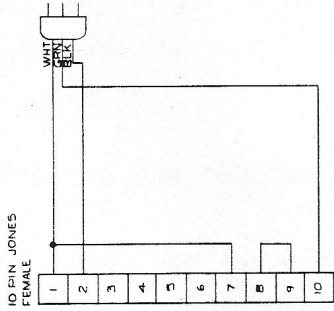

AMPEX 351

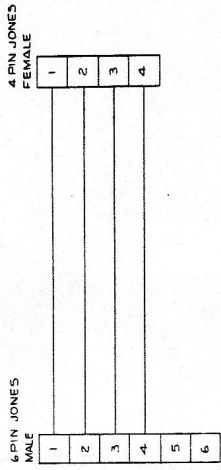

AMPEX 350 ADAPTER

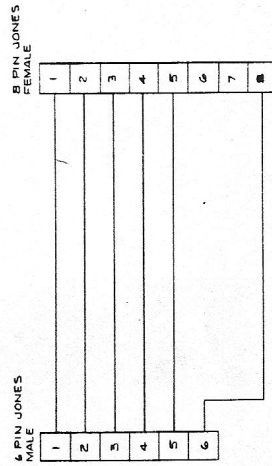

AMPEX AG-350 ADAPTER

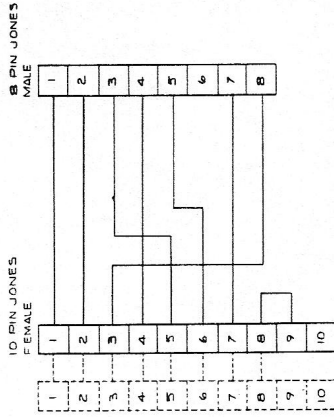

AMPEX AG-440

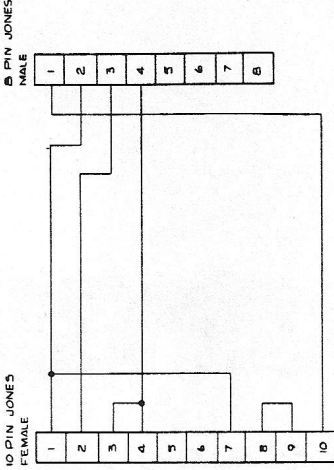

AMPEX FR-1100

| | | | |
|-----------------------|-----------------------|---------------------|----------------|
| 370 | FAK 14-20-91 | INDVONICS | DATE: 08-28-91 |
| 380 | APPROVED: [Signature] | FILE # 161200 | REV: 001 |
| FOR ANALYSIS | | INTERCONNECT CABLES | |
| BY: [Signature] | | DATE: 08-28-91 | REV: 001 |
| APPROVED: [Signature] | | DATE: 08-28-91 | REV: 001 |